

FEIDER



ROBOT VACUUM MOP CLEANER 3 IN 1
FRVC2
INSTRUCTION MANUAL

CAUTION: Read this manual before using this machine!

CONTENTS

1. IMPORTANT SAFETY INFORMATION.....	3
2. PRODUCT INTRODUCTION.....	6
3. INSTALLATION.....	7
4. OPERATING INSTRUCTIONS.....	9
5. MAINTENANCE AND CLEAN.....	11
6. NORMAL QUESTIONS.....	17
7. TROUBLESHOOTING.....	18
8. SPECIFICATIONS	18
9. DISPOSAL.....	19
10. DECLARATION OF CONFORMITY.....	20
11. WARRANTY.....	21
12. PRODUCT FAILURE.....	22
13. WARRANTY EXCLUSIONS.....	23

1. IMPORTANT SAFETY INFORMATION

This appliance can be used by children aged from 8 years and above and persons with reduced physical, sensory or mental capabilities or lack of experience and knowledge if they have been given supervision or instruction concerning use of the appliance in a safe way and understand the hazards involved. Children shall not play with the appliance. Cleaning and user maintenance shall not be made by children without supervision.

The Smart Vacuum Cleaner must be used in accordance with the directions in this Instruction Manual. We cannot be held liable or responsible for any damages or injuries caused by improper use.

To reduce the risk of injury or damage, keep these safety precautions in mind when setting up, using and maintaining your Smart Vacuum Cleaner:

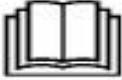
-  Read all safety and operating instructions before operating your Smart Vacuum Cleaner.
- Retain the safety and operating instructions for future reference.
- Heed all warnings on your Smart Vacuum, battery, charging Dock and in the owner's manual.
- Follow all operating and use instructions.
- the appliance is only to be used with the power supply unit provided with the appliance.
- The appliance must only be supplied at safety extra low voltage corresponding to the marking on the

appliance.



1.1 USER CAUTIONS

- The Smart Vacuum Cleaner is for indoor use only. Do not use the Smart Vacuum Cleaner outdoor, commercial or industrial environments.
- Before using the Smart Vacuum Cleaner, pick up objects like clothing, loose papers, pull cords for blinds or curtains, power cords and any fragile objects.
- The Smart Vacuum Cleaner is not a toy. Do not sit or stand on the Smart Vacuum Cleaner. Small children and pets should be supervised when the Smart Vacuum Cleaner is operating.
- Store and operate the Smart Vacuum Cleaner in room temperature environments only. Avoid any cold or heat. Operate the robot between -10°C to 50°C.
- Do not use the Smart Vacuum Cleaner to pick up anything that is burning or smoking.
- Do not use the Smart Vacuum Cleaner to pick up spills, bleach, paint, chemicals or anything wet.
- If the room to be cleaned contains a balcony, a physical barrier should be used to prevent access to the balcony and ensure safe operation.
- Do not place anything on top of the Smart Vacuum Cleaner.
- Be aware that the Smart Vacuum Cleaner moves on its own. Be careful when walking in the area that the Smart Vacuum Cleaner is operating in to avoid stepping on it.
- Do not operate the Smart Vacuum Cleaner in areas

with exposed electrical outlets in the floor.

-  Detachable supply unit.
- **WARNING:** For the purposes of recharging the battery, only use the detachable supply unit provided (Automatic dirt disposal C1) with this appliance.

1.2 BATTERY CARE & CHARGING

- Charge using a standard outlet only. This product may not be used with any type of power converter. The use of power converter will immediately void the warranty.
-  Before charging, read the instructions.
-  Charge the appliance only indoor.
- The Charging Dock may be protected with a surge protector in the event of severe electrical storms.
- Never handle or touch the Charging Dock or cables with wet hands.
- Always remove the Smart Vacuum Cleaner from the Charging Dock before cleaning or maintaining it.
- The Smart Vacuum Cleaner contains Li-ion rechargeable batteries, be sure to never open, pierce or damage the batteries.
- Do not wet the battery compartment.
- If the batteries are leaking, stop the Smart Vacuum Cleaner use immediately and contact customer service.
- Regarding the charging operation, refer to the paragraph below.

- This appliance contains batteries that are only replaceable by skilled persons.
- Only to charge the battery in this appliance. Do not recharge non-rechargeable batteries.
- If the supply cord is damaged, it must be replaced by the manufacturer, its service agent or similarly qualified persons in order to avoid a hazard.

2. PRODUCT INTRODUCTION

2.1 HOST

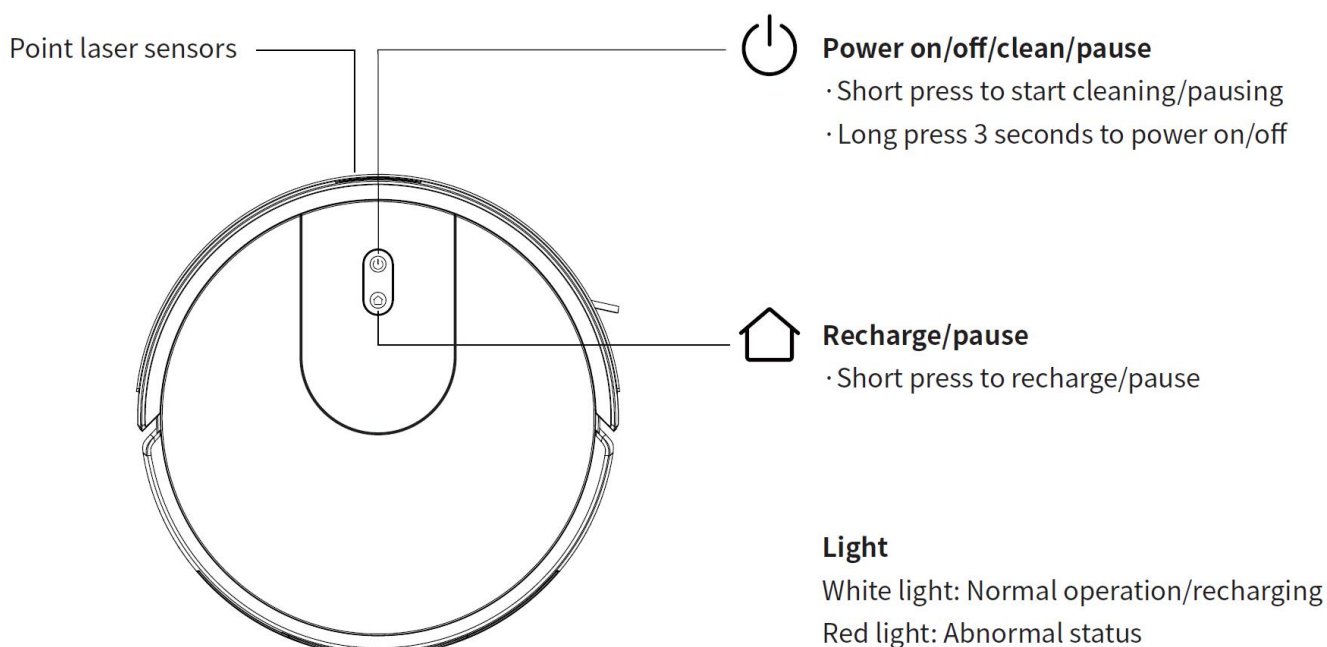

2.2 SENSOR AND STRUCTURE

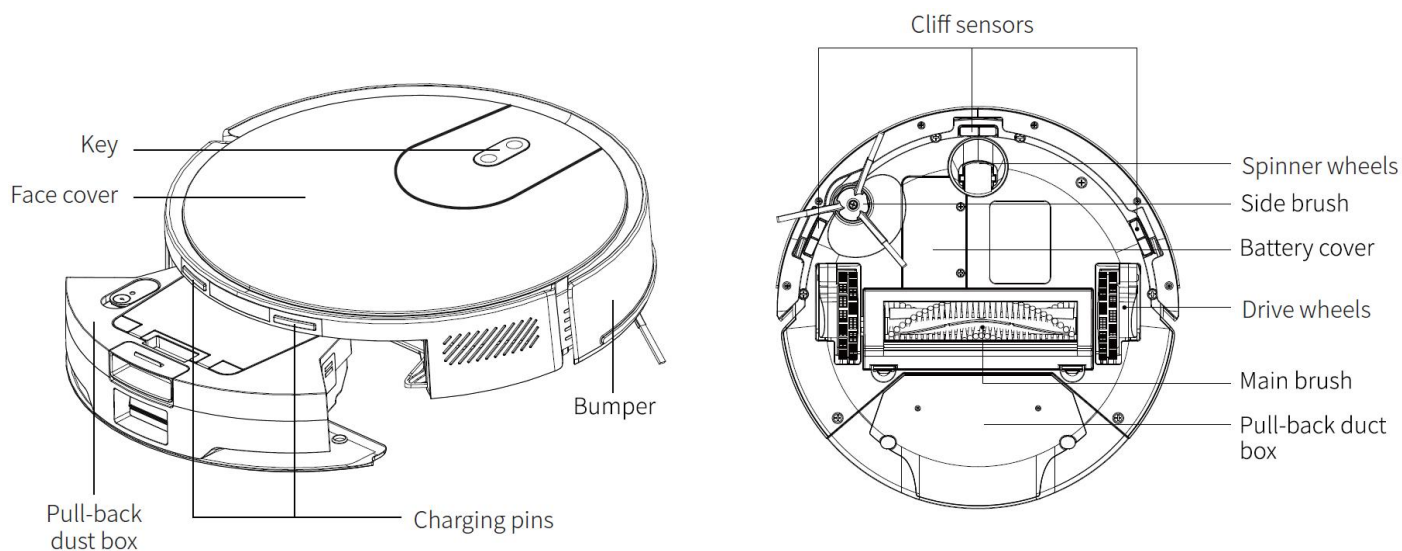

2.3 AUTOMATIC DIRT DISPOSAL

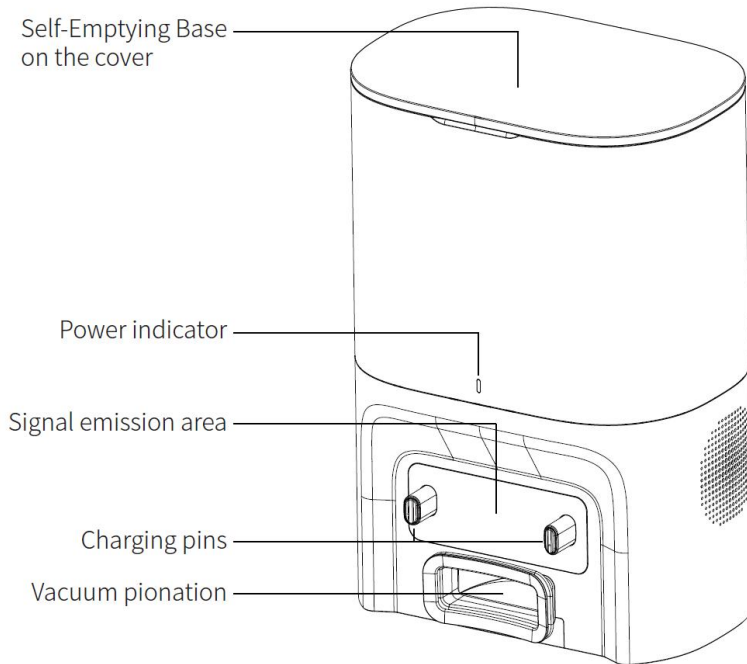

Power indicator

Solid on: Normal operation, fully charged

OFF: The power is not connected

Breathing: Charging

Flashing: The dust bag is not in place, and the fan is abnormal

2.4 BASE ACCESSORIES LIST

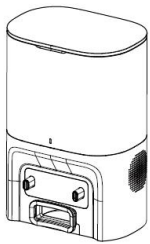

Self-Emptying Base×1

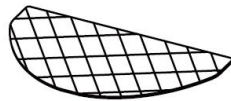

Mop×1

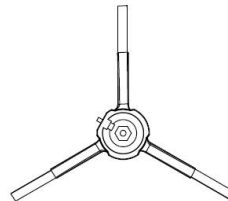

Side Brush ×1

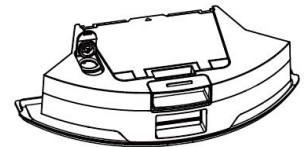

2 in 1 water tank×1

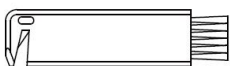

Cleaning brush×1

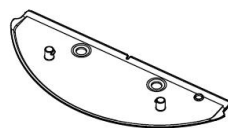

Mop bracket ×1

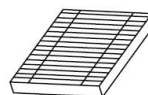

HEPA Strainer ×1



Dust bag×1



Instructions ×1

3. INSTALLATION

1. Please clean up the wires, hard objects, sharp objects (such as iron nails, glass) and other debris scattered on the ground before starting, and remove the easy, fragile, valuable and potentially dangerous items. Avoid personal injury or property damage caused by entanglement, stuck, dragged or bumped by the machine.
2. If the product is used in a suspended environment, set up guardrails to prevent the device from accidentally falling or pushing items to fall, causing damage to people or property.

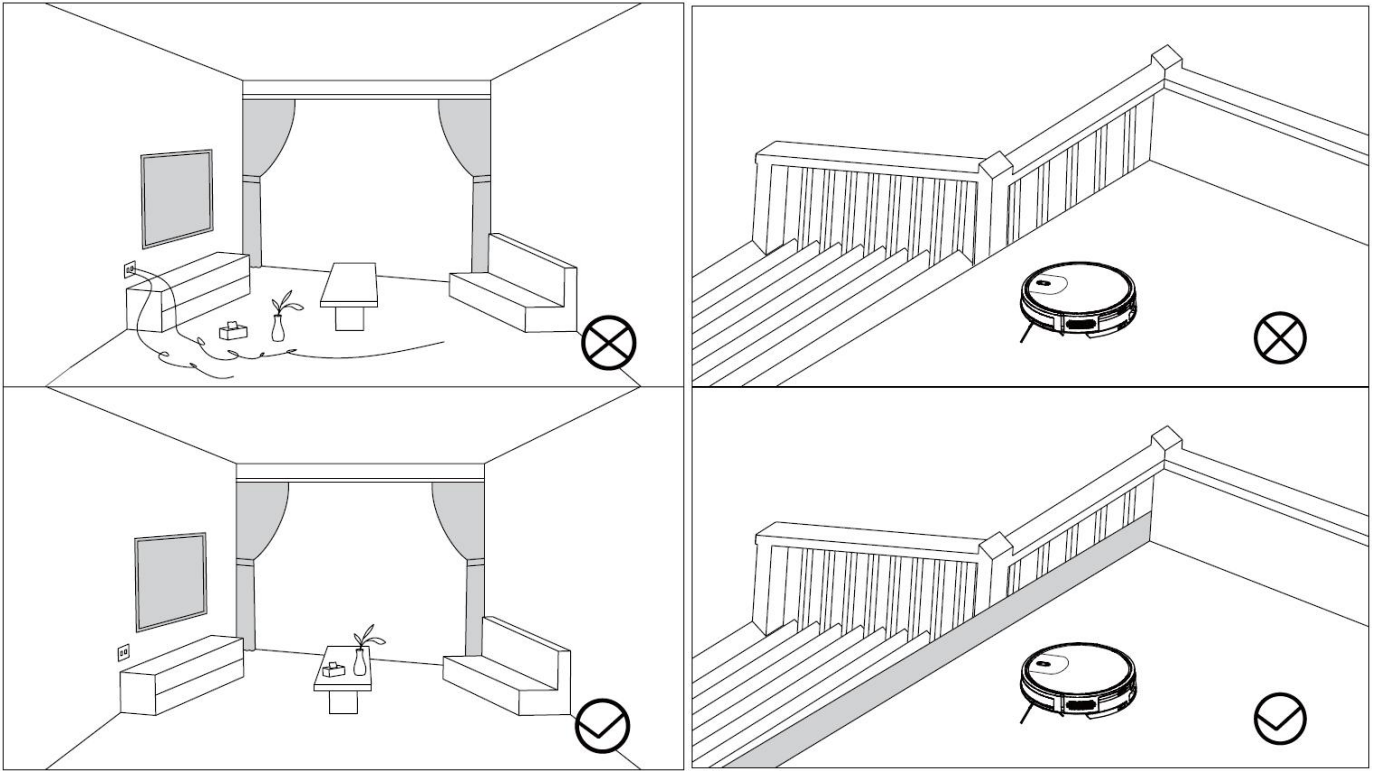

Prompt:

- During the first cleaning process, it is recommended to follow the host throughout the process to assist in dealing with some possible small problems, and the host can be cleaned smoothly in the future cleaning.
 - If some areas do not need to be cleaned or may be stuck, you can set a forbidden area in the mobile APP to block the host from entering the above areas.
 - Do not let the robot suck up hard or sharp objects (such as decoration waste, glass, iron nails, etc.), otherwise it may scratch the robot and the ground.
3. Place the Self-Emptying Base against the wall, and ensure that there are no obstructions within 0.5 meters on both sides and 1.5 meters in front of you. Wrap the excess wire around the spool and plug it in.

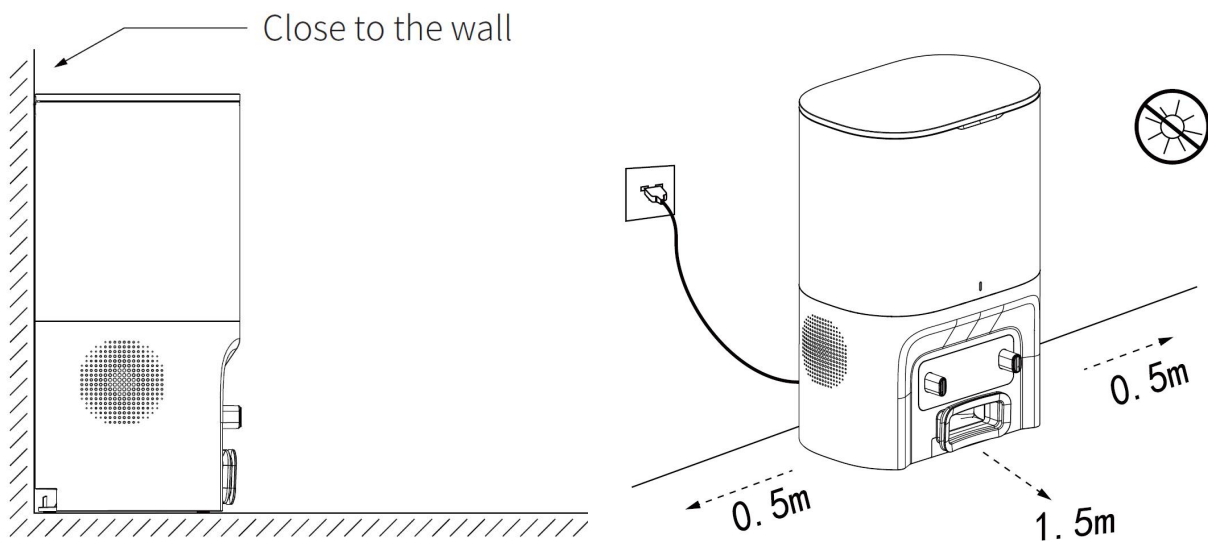

4. Before use, please put the main unit on the Self-Emptying Base to charge, and then use it after it is fully charged.

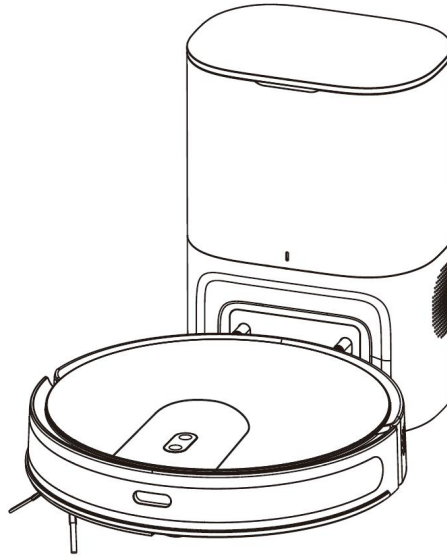

Note:

Sunlight exposure will interfere with the recharge signal, which may cause the host to be unable to return to the Self-Emptying Base, ensure that there is more than 0.5 meters on both sides of the Self-Emptying Base and more than 1.5 meters in front of the space, and the power cord hanging on the ground may be dragged by the host, causing the Self-Emptying Base to lose power.

5. Power on and charge

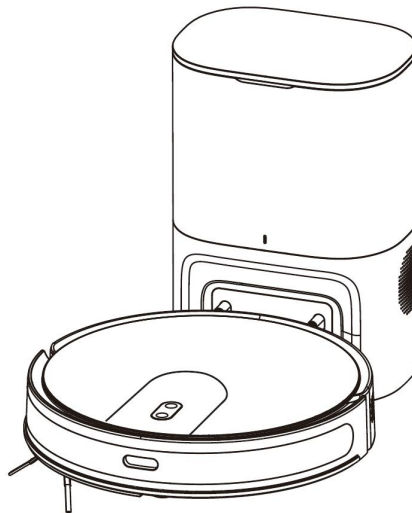

Press  and hold the button to turn on, wait for the indicator light to be always on, and then lean the host on the Self-Emptying Base to charge, and the language prompt "charging" indicates that charging is started.



Note: The battery is insufficient and cannot be turned on, please put the host on the Self-Emptying Base, and the device will automatically turn on.



4. OPERATION INSTRUCTIONS

4.1 POWER ON/OFF

Press  and hold the button for 3 seconds, the indicator light will light up, and the power on will be successful. When the machine is standby, press  and hold the button for 3 seconds, the indicator light will be off, and the machine will be turned off.

Note: The console cannot be powered off while it is charging.

Reset WIFI

At the same time, long press  and  for 3 seconds, and the voice prompt “WIFI has been reset ” is heard. The white lights of the power button flash, and the robot enters the waiting state for connection. After the connection is completed, the white lights of the power button are steady on.

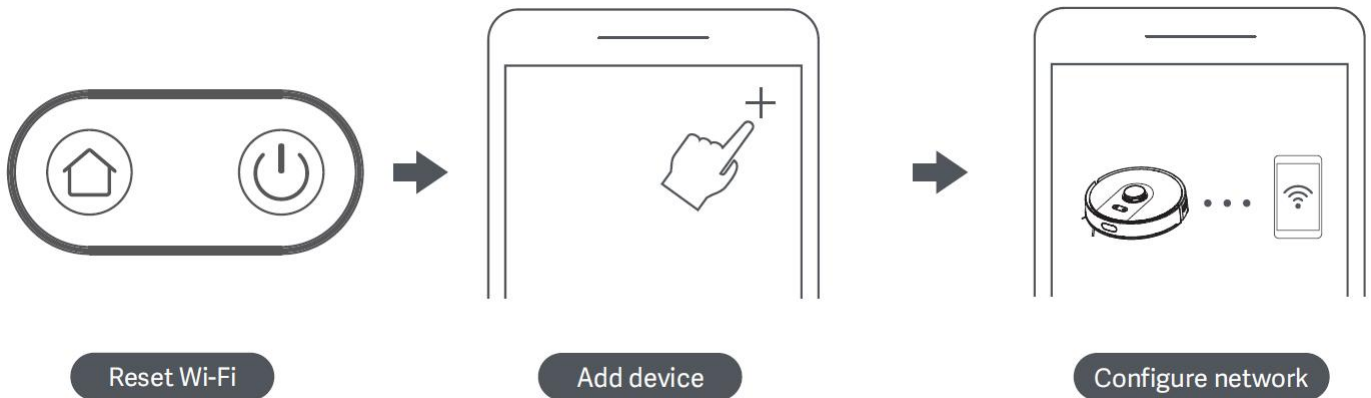

Tips: Only WIFI networks in the 2.4Ghz band are support.

5. MAINTENANCE AND CLEAN

5.1 ROUTINE MAINTENANCE

Main brush (Weekly cleaning recommended)

1. Flip the machine and hold down the buckle on the main brush cover and take out the main brush.

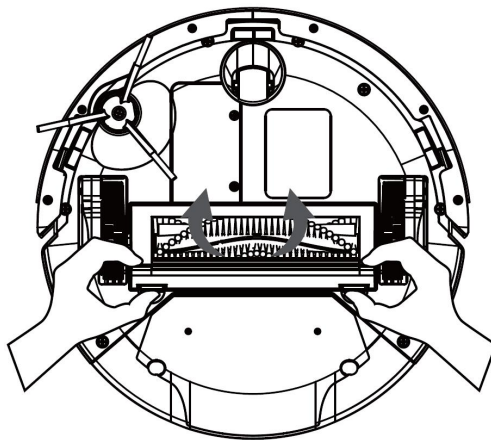

2. Remove the main brush.

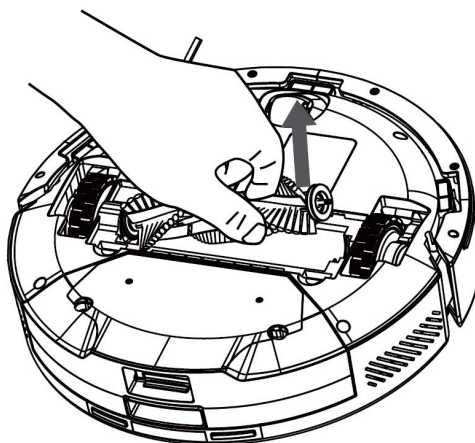

3. Use the matching cleaning brush to sweep away the dust in the main brush and the main brush cavity, and then Clean up the tangles on the main brush.

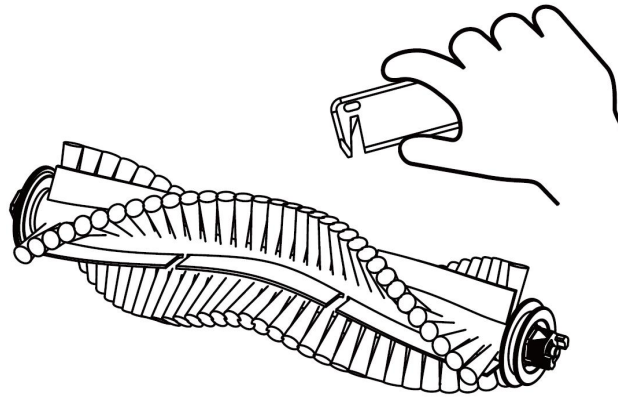

Edge brush (Weekly cleaning recommended)

1. Flip the machine and use a Phillips screwdriver to screw out the side brush screws and pull out the side brush.
2. Clean the tangled hairs and dirt and put it back on, and tighten the screws.

Note: It is recommended to replace the side brush every 3 months to ensure the cleaning effect.

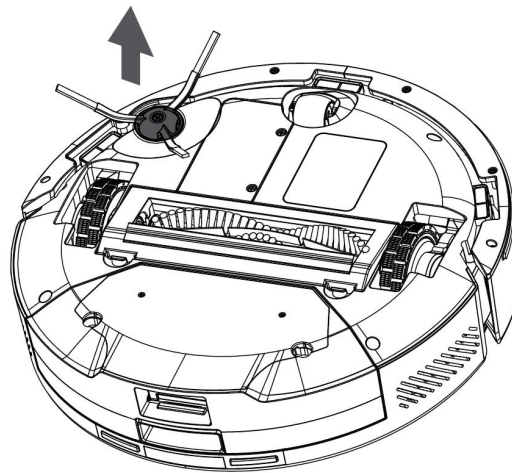

Dustbin and filter (Recommended after each cleaning)

1. From the back of the machine, press and hold and take out the dust box.
2. Press and hold the dust bin switch to open the dust bin and dump the garbage.

Clean the dustbin (It is recommended to clean it once a week)

1. After a long period of use, remove the filter screen and HEPA filter

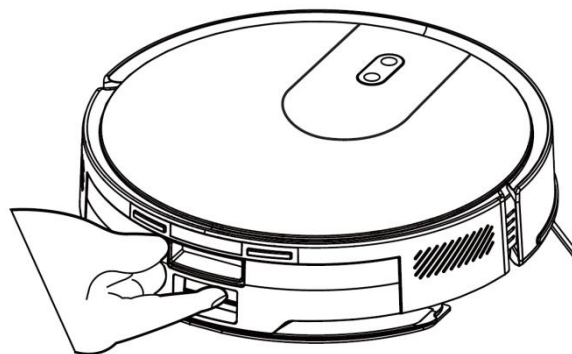

2. Put the removed primary filter screen and dust box under the faucet to rinse (HEPA filter screen cannot be washed)

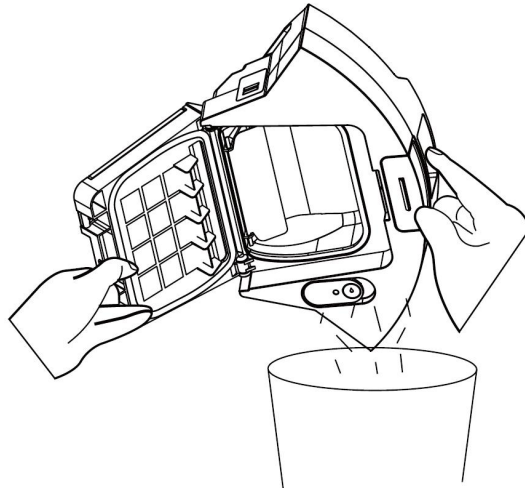

3. Dry the water droplets after cleaning, dry the filter screen and dust box, and wait until it is completely dry before use.

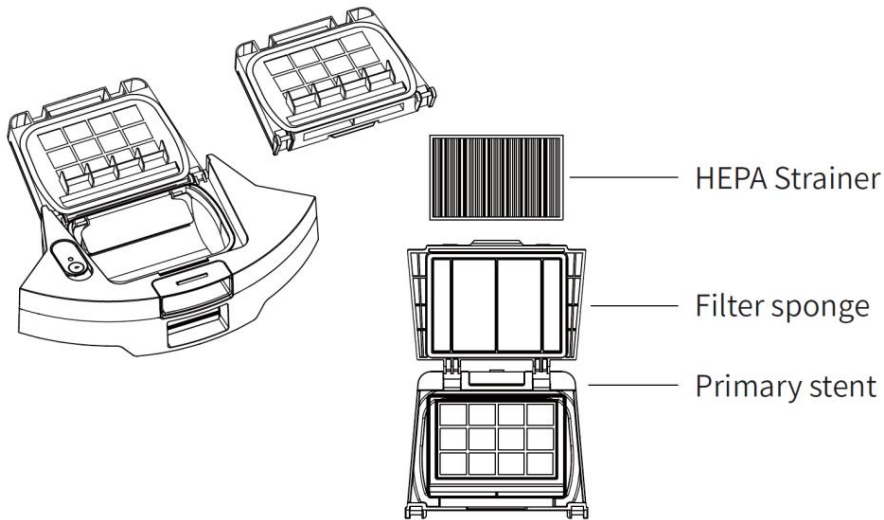

Note:

- Please rinse with clean water and do not add any detergent. Do not use brushes, fingers to clean the filter.
- Allow the strainer to dry thoroughly for at least 24 hours. It is recommended to replace one set of filters every 3 months.

Water tank use

Do not use the mopping function on the carpet, after mopping the floor, please empty the water tank and remove the rag in time.

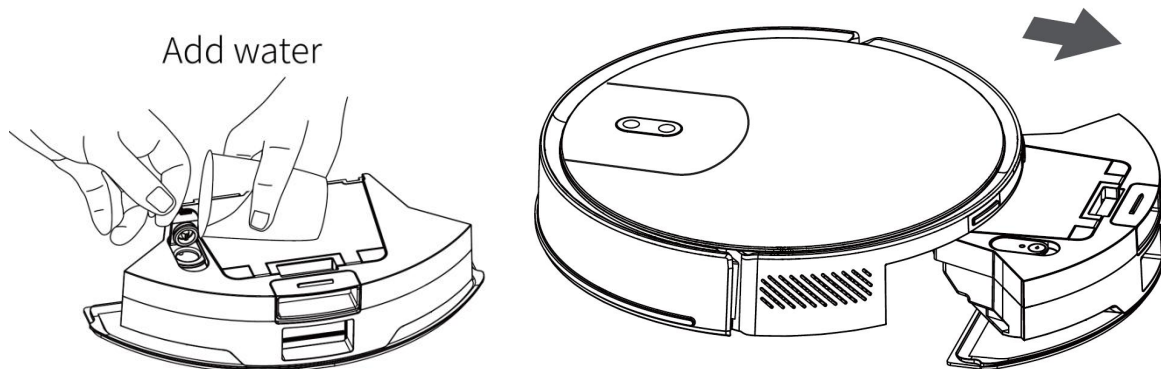

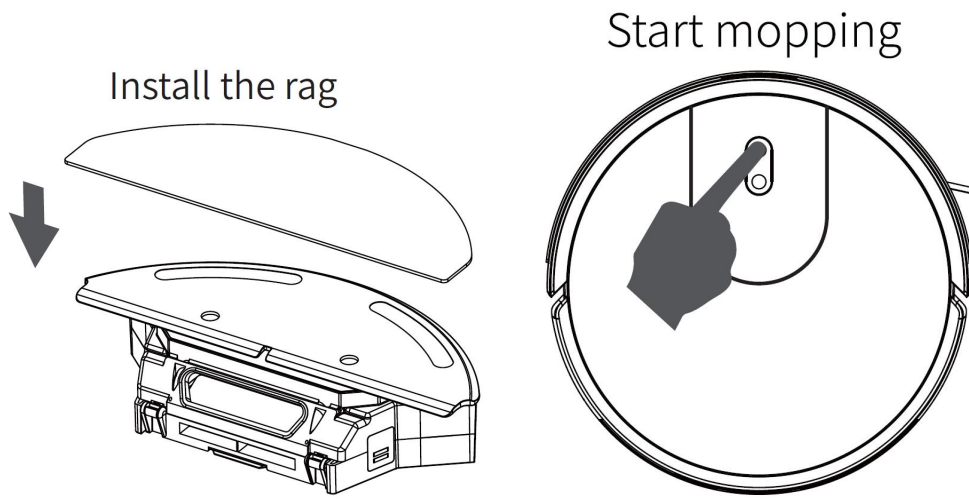

Clean

Cleaning spot laser detection sensor (monthly cleaning recommended)

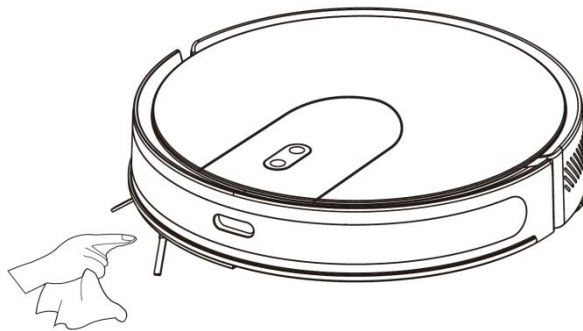

Cleanup cliff sensor (monthly cleaning is recommended)

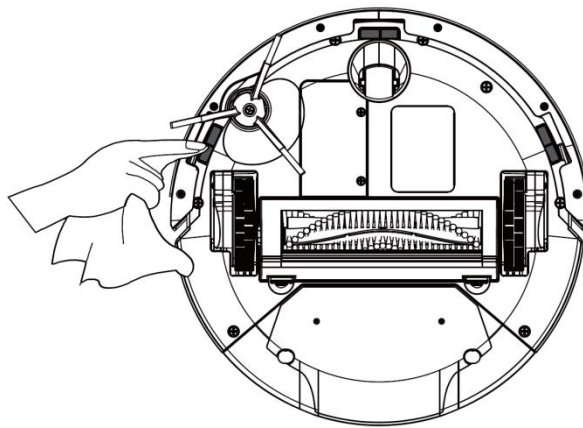

Clean the main unit charging contacts (it is recommended to clean them once a month)

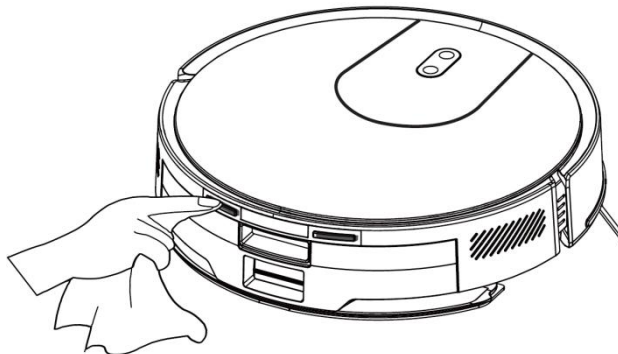

Clean the signal transmission area and charging contacts of the Self-Emptying Base (it is recommended to clean it once a month)



5.2 DAILY MAINTENANCE

Dust bag replacement

When the device prompts that the dust bag is full, please replace the dust bag in time. Dust bags are consumables and can be purchased through officially designated channels.

1. Open the upper lid

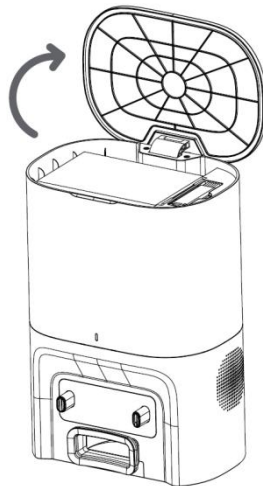

2. Lift the dust bag upwards

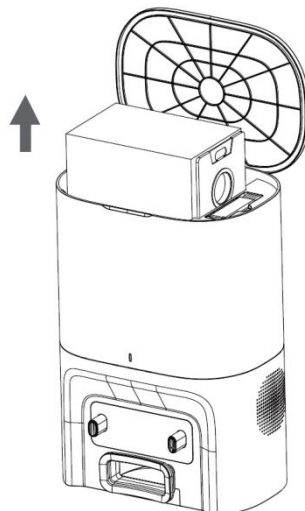

3. Throw the dust bag in the trash

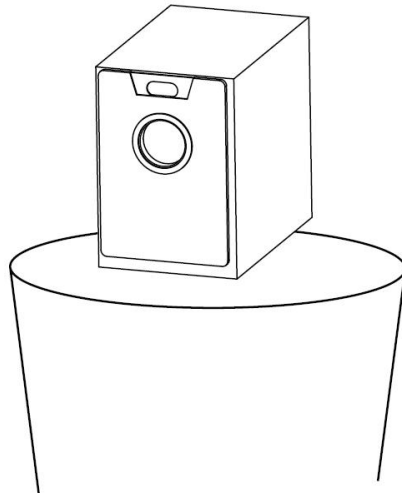

4. Install a new dust bag

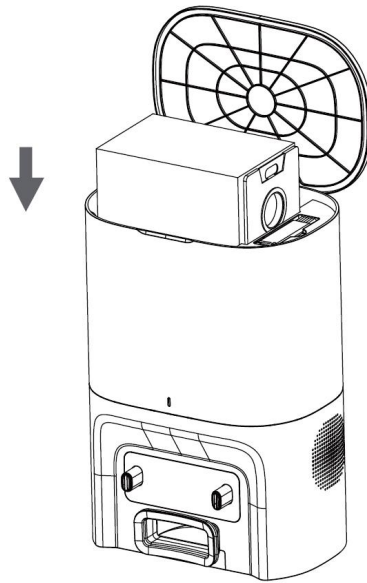

5. Close the lid of the barrel

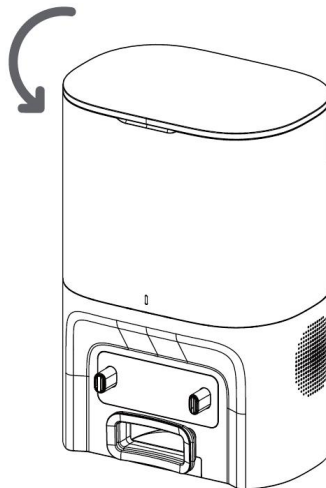

Clean the dust collection channel and filter port

If the dust collection effect is not good after replacing the dust bag, it is recommended to unplug the power plug and reverse the device to check whether there is any foreign matter blocking in the dust tunnel. Please use a screwdriver to remove the transparent cover of the dust duct to clean out foreign objects, take out the dust bag to check whether there are foreign objects in the filter port and clean the filter port.

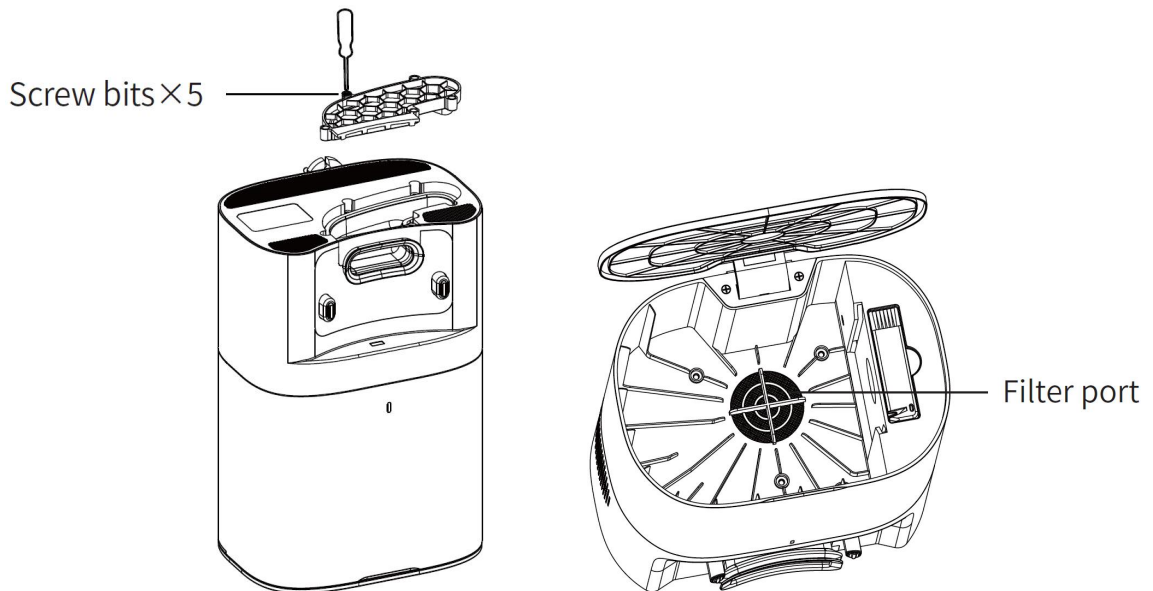

Firmware upgrades

Through the mobile phone APP, enter the firmware upgrade function, and after the new firmware is detected, Follow the prompts to upgrade, the firmware requires $\geq 30\%$ power during the upgrade, it is recommended to place the device on the Self-Emptying Base for upgrade.

Maintenance of the battery

1. The device has a built-in rechargeable lithium battery pack, in order to maintain the battery performance, please keep the host in a charged state for daily use, which is conducive to the best performance of the battery and does not lose excessive power.
2. If the device are not in use for a long time, please fully charge: make sure to turn it off before storing.
3. Charge at least once every 3 months to avoid damage caused by over-discharge of the battery.
4. The lithium battery can be charged at any time and can be used when fully charged.

6. NORMAL QUESTIONS

The type of question	Resolution
Crashed/Won't Turn On	If the battery is low, place the device on the charging dock, align it with the contact point, and the device will automatically power on. If the ambient temperature is lower than 0°C , please use it in an environment of $0\sim 40^{\circ}\text{C}$. Please check whether the power plug of the device is connected properly and confirm that the power supply to the socket is normal.
Unable to charge	If the contact is bad, please clean the dirt on the charging contact point, or unplug the side brush. If the device is too far away from the charging cradle, please place the main unit near the charging cradle and try it.
Cannot be recharged	Shut down and restart.
Abnormal behavior	There may be foreign objects entangled in the main brush, side brush or wheel, please clean it up after stopping.
Reduced cleaning ability or falling ash	The filter is clogged, please clean or replace it. The main brush is entangled by foreign objects, please clean the main brush.

Unable to connect to WIFI	The WIFI signal is not good, please make sure the device is in a good WIFI (2.4G frequency band, 5G does not support) signal coverage area. Please reset the WIFI and download the latest mobile APP to try to connect again. Check if your password has been entered incorrectly.
Scheduled cleaning appointments are not valid	If the battery is insufficient, the remaining battery $\geq 15\%$ will start the scheduled cleaning.

7. TROUBLESHOOTING

Prompt tone	The resolution
Please put back the dust box.	The 2 in 1 dustbin & watertank is removed. Please reinstall it.
Please place the machine on level ground to start.	The robot is suspended in the air, please move the robot to a flat ground before starting.
Please stay away from the restricted area before starting.	Please move the robot to a non-restricted area before start cleaning.
The machine is trapped, please move.	Check for entanglement or obstacles, and promptly clean the items that affect the work of robot.
Positioning failed, rebuild the map.	The map data is lost, plan the path again.
Seems something wrong with the main wheel.	Main wheel is stuck or entangled. Please check the main wheels and clean it.
Please check if the main brush is stuck.	Main brush is stuck or wrapped, please check the main brush and clean it.
Please check if the side brush is stuck.	The side brush is stuck or wrapped, please check the side brush and clean it.
Please check the front anti-collision sensor.	The anti-collision sensor is abnormal, please clean, wipe and maintain it.
Please check the right sensor along the wall.	The sensor along the wall is abnormal, please clean, wipe and maintain it.
Please check if the crash barrier is stuck.	The collision sensor is stuck, please clean and maintain it.

If the problems cannot be solved according to the above operation, please contact the after-sales service.

8. SPECIFICATIONS

HOST	Product model	FRVC2
	Rated voltage	14.4 Vd.c.
	Rated power	45W
	Battery type	4S1P 2600mAh lithium battery
	Dust bin capacity	250 ml
	Water tank capacity	300 ml
	Charging time	300 min

	Frequency band(s)	Wi-Fi: 2412 - 2472 MHz
	Maximum radio-frequency power	Wi-Fi: 16.681 dBm
	Dimensions	330x330x83mm
	Standby mode	0.5 W
	Networked Standby mode	1.9 W
	Time taken to automatically reach networked standby	19 minutes
Automatic dirt disposal	Rated inputs	220-240V~, 50/60Hz Charging state: 0.2A Dirt disposal state: 3.5A
	Rated outputs	20Vd.c. 0.6A
	Power	650W
	Dust bag capacity	3 L
	Dimensions	228x162x330mm

9. DISPOSAL



Batteries and electrical/electronic products should not be thrown away with household products. When scrapped, batteries and electrical/electronic products must be collected separately and disposed of at designated collection points. Consult your local authorities or retailer for advice on recycling.

Recycling and disposal



The marking of this device (symbol of a crossed-out dustbin) complies with European Directive 2012/19/EU relating to "used electrical and electronic equipment". This marking means that this equipment, at the end of its useful life, cannot be disposed of with other household waste. The user is required to deliver it to operators who collect used electrical and electronic equipment. Collection operators, including local collection points, shops and local authorities, create an appropriate system for collecting equipment. Appropriate collection of used electrical and electronic equipment helps avoid harmful impacts on human health and the environment, resulting from the presence of hazardous components, as well as from improper storage and treatment of this equipment.



The battery is Li-Ion type. To preserve natural resources, please recycle or dispose of the battery pack properly. Consult your local waste authority for information regarding available recycling and/of disposal options. Discharge your battery pack by operating your tool, then remove the battery pack from the tool and cover the battery pack connections with heavy duty adhesive tape to prevent short circuit and energy discharge.

10. DECLARATION OF CONFORMITY



SODILOG SAS
4 RUE CURIE, CS 91617 68016 COLMAR CEDEX FRANCE

ROBOTIC VACUUM MOP CLEANER 3 IN 1
FRVC2

Serial number: 20250622736-20250624835

This declaration of conformity is issued under the sole responsibility of the manufacturer.
The object of the declaration described above is in conformity with the relevant Union
harmonisation legislation: Directive 2014/53/EU

Applicable harmonised standards:

EN 60335-1: 2012+A11:2014+A13:2017+A1:2019+A14:2019+A2:2019+A15:2021+A16:2023 EN IEC 60335-2-2: 2023+A11:2023 EN 62233: 2008
EN IEC 62311: 2020 EN 50665: 2017
ETSI EN 301 489-1 V2.2.3: 2019-11 ETSI EN 301 489-17 V3.2.4: 2020-09
ETSI EN 300 328 V2.2.2: 2019-07
EN IEC 55014-1: 2021 EN IEC 55014-2: 2021 EN IEC 61000-3-2: 2019+A1:2021 EN 61000-3-3: 2013+A1:2019+A2:2021

Responsible of technical file : M. Olivier Patriarca
COLMAR CEDEX, 21/03/2025

Jacques Masson/PDG

11. WARRANTY

The manufacturer guarantees the product against defects in material and workmanship for a period of 5 years from the date of the original purchase. It can be extended by one year if the user subscribes to website of myswap. The warranty only applies if the product is for household use. The warranty does not cover breakdowns due to normal wear and tear.

The manufacturer agrees to replace parts identified as defective by the designated distributor. The manufacturer does not accept responsibility for the replacement of the machine, in whole or in part, and/or ensuing damage.

The warranty does not cover breakdowns due to:

- insufficient maintenance.
- abnormal assembly, adjustment or operations of the product.
- parts subject to normal wear and tear.

The warranty does not extend to:

- shipping and packaging costs.
- using the tool for a purpose other than that for which it was designed.
- the use and maintenance of the machine done in a manner not described in the user manual.

Due to our policy of continuous product improvement, we reserve the right to alter or change specifications without notice. Consequently, the product may be different from the information contained therein, but a modification will be undertaken without notice if it is recognized as an improvement of the preceding characteristic.

READ THE MANUAL CAREFULLY BEFORE USING THE MACHINE.

When ordering spare parts, please indicate the part number or code, you can find this in the spare parts list in this manual. Keep the purchase receipt; without it, the warranty is invalid. To help you with your product, we invite you to contact us by phone or via our website:

+33 (0)9.70.75.30.30

<https://services.swap-europe.com/contact>

You must create a "ticket" via the web platform.

- Register or create your account.
- Indicate the reference of the tool.
- Choose the subject of your request.
- Describe your problem.

Attach these files: invoice or sales receipt, photo of the identification plate (serial number), photo of the part you need (for example: pins on the transformer plug which are broken).



swap

12. PRODUCT FAILURE

WHAT TO DO IF MY MACHINE BREAKS DOWN?

If you bought your product in a store:

- Make sure that your machine is complete with all accessories supplied, and clean! If this is not the case, the repairer will refuse the machine.
- Go to the store with the complete machine and with the receipt or invoice.

If you bought your product on a website:

- Make sure that your machine is complete with all accessories supplied, and clean! If this is not the case, the repairer will refuse the machine.
- Create a SWAP-Europe service ticket on the site: <https://services.swap-europe.com> When making the request on SWAP-Europe, you must attach the invoice and the photo of the nameplate (serial number).

Contact the repair station to make sure it is available before dropping off the machine.

Go to the repair station with the complete machine packed, accompanied by the purchase invoice and the station support sheet downloadable after the service request is completed on the SWAP-Europe site

Please keep your original packaging to allow for after-sales service returns or pack your machine with a similar cardboard box of the same dimensions.

For any question concerning our after-sales service you can make a request on our website <https://services.swap-europe.com>

Our hotline remains available at +33 (9) 70 75 30 30.



13. WARRANTY EXCLUSIONS

THE WARRANTY DOES NOT COVER:

- Start-up and setting up of the product.
- Damage resulting from normal wear and tear of the product.
- Damage resulting from improper use of the product.
- Damage resulting from assembly or start-up not in accordance with the user manual.
- Periodic and standard maintenance events.
- Actions of modification and dismantling that directly void the warranty.
- Products whose original authentication marking (brand, serial number) has been degraded, altered or withdrawn.
- Replacement of consumables.
- The use of non-original parts.
- Breakage of parts following impacts or projections.
- Accessories breakdowns.
- Defects and their consequences linked to any external cause.
- Loss of components and loss due to insufficient screwing.
- Cutting components and any damage related to the loosening of parts.
- Overload or overheating.
- Poor power supply quality: faulty voltage, voltage error, etc.
- Damages resulting from the deprivation of enjoyment of the product during the time necessary for repairs and more generally the costs related to the immobilization of the product.
- The costs of a second opinion established by a third party following an estimate by a SWAP-Europe repair station
- The use of a product which would show a defect or a breakage which was not the subject of an immediate report and/or repair with the services of SWAP-Europe.
- Deterioration linked to transport and storage*.

* In accordance with transport legislation, damage related to transport must be declared to carriers within 48 hours maximum after observation by registered letter with acknowledgement of receipt. This document is a supplement to your notice, a non-exhaustive list.

Attention: all orders must be checked in the presence of the delivery person. In case of refusal by the delivery person, it you must simply refuse the delivery and notify your refusal.

Reminder: the reserves do not exclude the notification by registered letter with acknowledgement within 72 hours.

Information:

Thermal devices must be wintered each season (service available on the SWAP-Europe site). Batteries must be charged before being stored.

FEIDER



SODILOG SAS
4 RUE CURIE, CS 91617 68016 COLMAR CEDEX FRANCE
Made in PRC